

Livestock Trailers

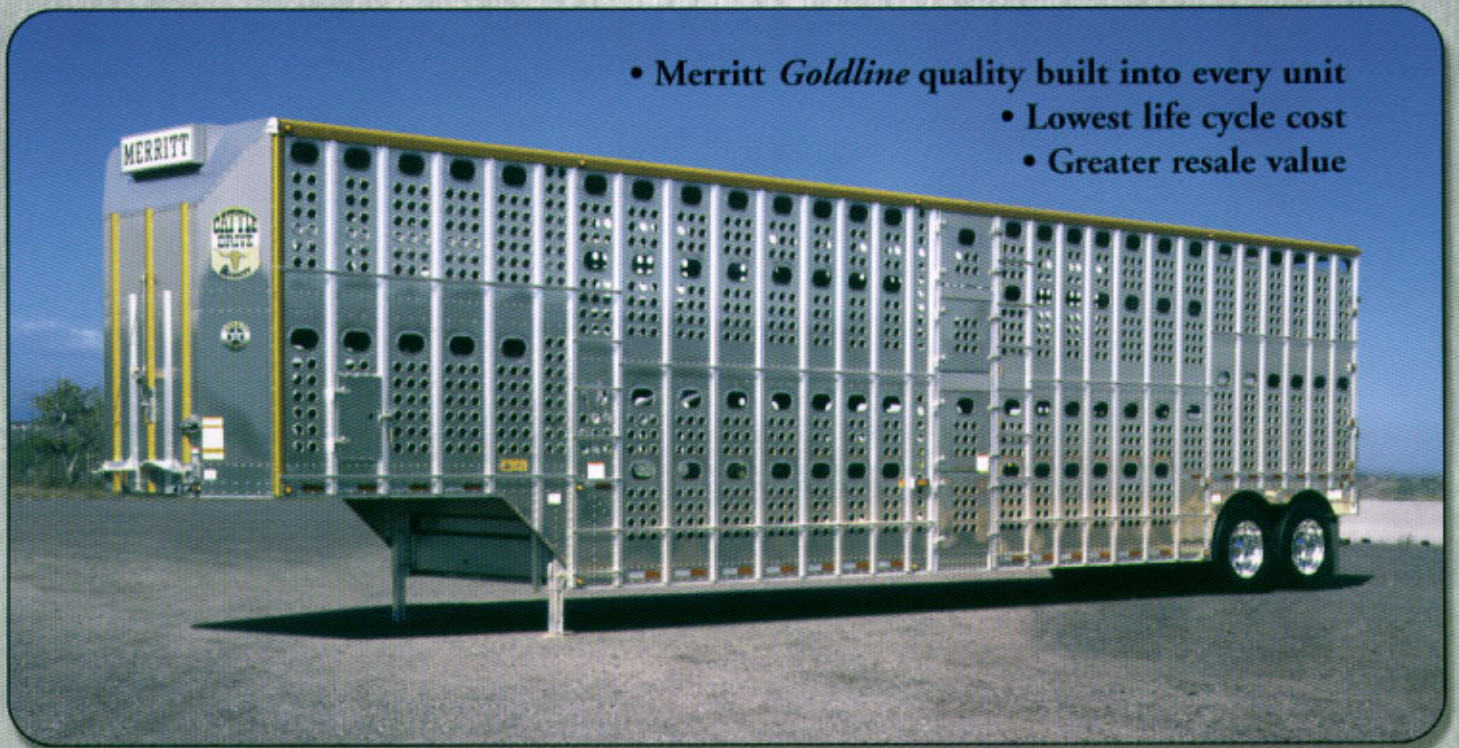

## Cattle Only

- Merritt *Goldline* quality built into every unit
- Lowest life cycle cost
- Greater resale value



### *Merritt Standard Features*

- **Bull Nose:** Innovative design couples good looks with better fuel economy and results in a smooth inside surface that doesn't bruise livestock.
- **Welded Floors with 3" I-Beam Cross Members:** The strongest floor in the business is built with 3" I-beams welded to a thicker floor plate. I-Beam cross members won't flatten out after years of use and with no rivets to vibrate loose, the floor will stay in place. Closer rib spacing means better footing and fully overlapped top seams ensure fewer leaks. Working together they increase the usable life of your new Merritt.
- **Upgraded Running Gear:** Aluminum hubs, Centrifuse drums and extended service brakes mean lighter weight and lower life cycle costs. All are standard equipment on a Merritt trailer.
- **Roof Construction:** Merritt's roof is designed to haul livestock and is built w/.050 aluminum skin fully riveted to roof bows that will resist flexing and stop costly roof repairs. No gimmicks or van roofs here, only the time-tested best.
- **Sheet and Post Design:** High grade aluminum alloys that are heat treated to resist dents and tears and shines better than any trailer on the market today. This also provides unmatched inside width for maximum livestock comfort.
- **LED Lights:** Merritt again takes the lead in safety by being the first livestock trailer to be standard with LED lighting. Lower life cycle cost with longer harness life, fewer wiring problems and brighter lights mean lower maintenance cost.

***Legendary Merritt Toughness is Built into Every Merritt Trailer***





# CATTLE ONLY STANDARD SPECIFICATIONS

- Tapered front nose
- Punched, full height 30" wide roadside doors
- Clean-out door, lower driver-side front nose
- Feeder cattle rail, removable deck boards and storage rail
- Counterbalance front ramp, 60" wide (drop back optional)
- Left-hand rear roll up door with grab handle
- Rear doghouse with lay down lid
- Drop and swing door to doghouse
- Drains in rear basket face (1 each side)
- Pullout ramp to second deck
- Zinc plated steel rear impact guard, self draining (where required)
- Aluminum roof, fully riveted with over 2,200 bucked rivets
- Walk rails both sides with 3 side ladders and full ladder at center doors
- Air and electrical hook-up roadside front
- Load light switch front nose – 3 position
- Top and bottom center divide gates – hinged curbside
- Rear center 55" half gate – hinged roadside (operates with ramp lid closed or open)
- Rubber wear pads on all gates
- Zinc plated gate latches and hardware
- Stainless steel drop pins and auto-slam spool locks for gates
- "High-Grip" aluminum diamond plate floor – .112 thickness
- Six ribbed floor corrugations
- Sealed wiring harness with internal grounding
- Beehive-style LED marker lights
- 6 - 4" LED tail lights and oval LED turn signals
- Center rear 6" oval LED brake light
- High-output interior loading lights – 9 total
- Aluminum hubs – 10 hole uni-mount with grade 8 lug nuts
- Centrifuse brake drums with extended-life lining package
- 22,500# axles, 5" round with automatic slack adjusters
- ABS brakes with multiplexing system
- Single leaf springs (Hendrickson *Intraax* air ride available)
- Choice of wheels, tires and sizes



Welded 3" I beam cross members coupled with "Super High Grip" diamond plate floors with unsurpassed diamond height and edge sharpness and you have the long-life, leak-resistant floor that Merritt has always been known for.



Lower rear partition gate has been widened to 55" to help reduce bruising. You can operate the ramp lid with the gate open or closed for increased driver safety.



Front 60" wide counterbalance ramp makes loading and unloading quick and easy. Easily greased hinge pipes and nylon slide strips make it smooth to operate under any conditions.

### Dimensions:

Overall lengths: to 53'      Front frame: 10' 6" – 13'  
 Width: 102"      Rear frame: 9' – 17' Tri-Axle  
 Overall height: 13' 6" – 14'      Fifth wheel height: 45" – 49"

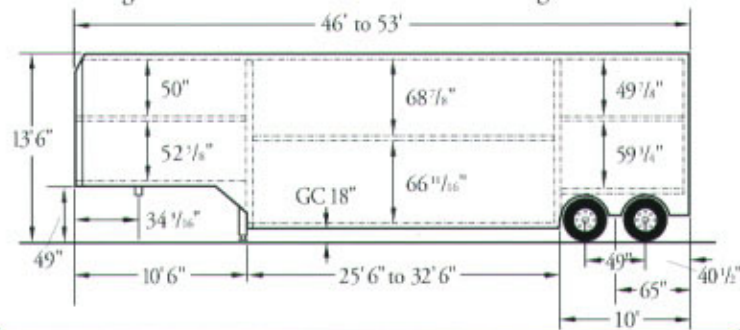

**Disclaimer Statement:** Merritt Equipment Co. reserves the right to make changes in materials, components, designs, equipment specifications and trailer models without notice. All visual specifications, representations, volumes and dimension references are based on the latest product offerings and are approximations available at the time of this publication. At no time will the information contained within this publication be used as the basis for resolving disputes.